

See page 2 for a description

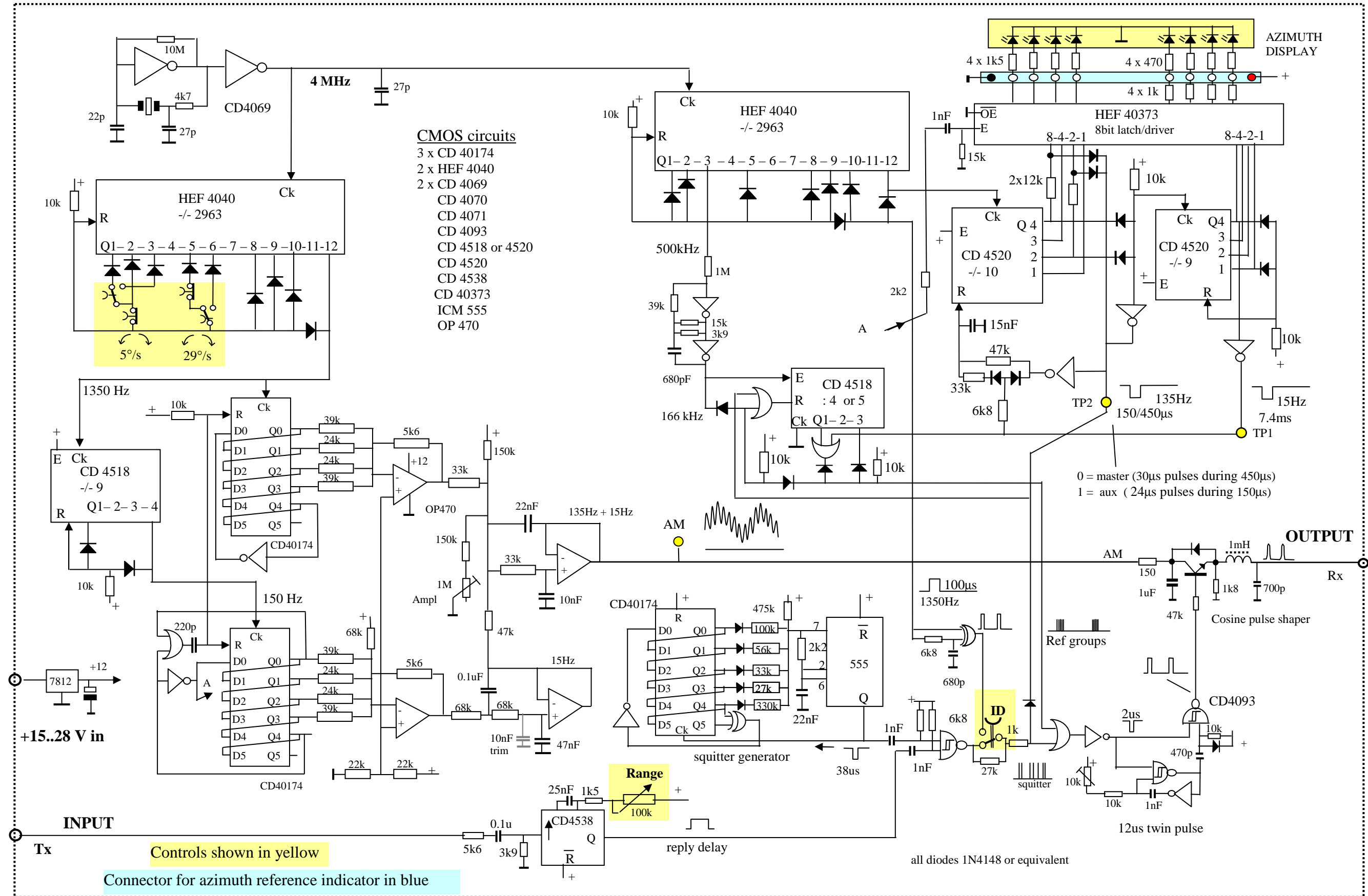

A TACAN beacon simulator

© 2007 K.Bouwknegt

This simple beacon simulator is made from standard CMOS circuits to test the ARN-21. Because this vintage TACAN set only has X channels, the simulator only produces X mode signals, i.e. twin pulses with 12 μs spacing, 30μs pulse spacing for the main ref group etc.

Bearing and distance can be set at will. Bearing is set with 4 pushbuttons giving fixed up/down rates of 5 or 29 °/s. The bearing is shown on 8 leds. Range is set with a potmeter. The ID tone is selected as long as the ID button is pushed.

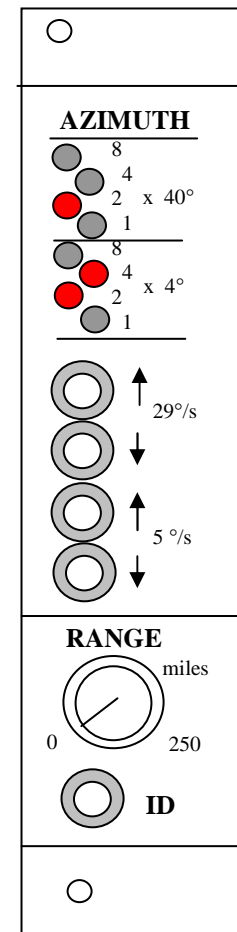

Connection to the AN/ARN-21
The simulator is supplied from +15...28Vdc, and provides a composite video signal with 15Hz and 135Hz amplitude modulated twin pulses, made-up of the main and aux ref groups, squitter, and of course the reply to the interrogation impulse of the set, tapped from the BNC blanking output on the front of the ARN-21. The output video signal is injected on the input of the 12us delay line on the video board of the RT220/ARN21.

Introduction

The basis for all timing is a single crystal at 4 MHz.. This frequency is divided by 2963 to get almost exactly 1350Hz. Further division by 10 and 9 gives the auxiliary and main reference bursts at 135Hz and 15Hz. In a second divider, the 4MHz is also divided by 2963, but as long as one of the

azimuth up/down buttons is pushed, the divisor is slightly different. The result, 1350Hz +/-something is divided down to 135Hz and 15Hz, in sequential counters, the outputs of them are summed up to get two sine waves. These are added to provide the typical pulse amplitude modulation of a TACAN signal.

A 63 “random” number generator is used to make the squitter pulses.

Timebase

The 4MHz Xtal oscillator cycles are counted in two 12 bit binary counters. When the counter outputs reach a specific bitpattern for the first time (101110 010 011 =2963), the counter is reset, and the proces repeats. For the first occurrence of a bitpattern, only the “ones” need to be checked. The tacan AM is derived from the first counter, while the reference bursts come from the second counter.

Bearing setting

As long as a button is pushed to change the bearing, the first counter has a slightly different divisor.

Nominal 2963= 101110 010 011 nom
Slow: 2966= 101110 010 110 - 5.3°/s
2960= 101110 010 000 + 5.3°/s
Fast: 2979= 101110 100 011 - 29°/s
2947= 101110 000 011 + 29°/s

Example: When the divisors differ by ±3, then the phase between the final 15Hz signals changes with $360^\circ \times 4\text{MHz} / (\pm 3 \times 10 \times 9) = \pm 5.333^\circ/\text{s}$
The ARN21B is specified to track at least 5°/s.

Amplitude modulation

To simulate the rotating antenna pattern of a TACAN beacon, the pulses must be amplitude modulated by a 15Hz and 135Hz sinewave. Each sinewave is made from 4 symmetrical squarewaves, derived from a 5 stage shift register. Four of the 5 Q outputs are used and added to a stepped wave, which has a special spectrum: the lowest harmonic is the tenth when the outer squarewaves to the inner square waves scale as $(\sqrt{5} - 1) : 2$. This is approximated with summing resistors of 39k2 and 24k3 from the E24 series.

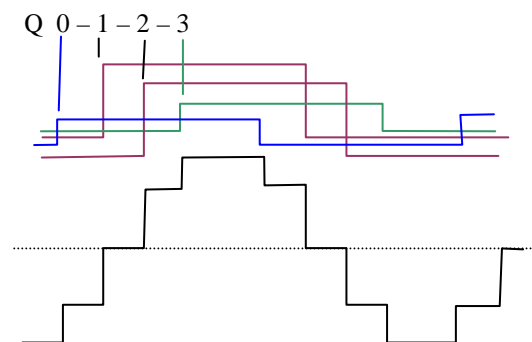

Each stepped wave is filtered to a sinewave with 1% distortion in a second order filter. The sinewaves are added to get the typical TACAN envelope.

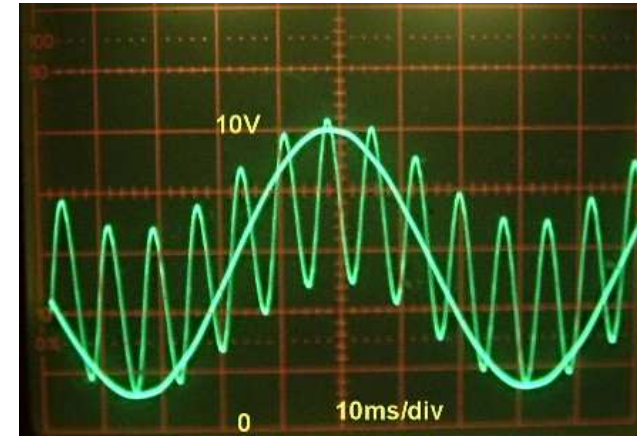

Reference bursts

On TP2, there is 135 times/sec a pulse. During this pulse there is either an auxiliary or a main ref burst, and squitter or replies are blocked. Outside this pulse, the 4-or-5 divider is held reset.

One out of 9 pulses on TP2 coincides with the pulse at TP1. This pulse at TP2 is wider (450μs) and filled with $166/5 = 33\text{kHz}$ (30us) pulses as master ref.

The other 8 pulses at TP2 are 160μs wide, and filled with $166/4 = 41.6\text{ kHz}$ (24μs) aux ref burst. There are 12 resp. 6 pulses in each burst. All pulses are 3μs wide and derived from a 166kHz signal (24 cycles of the 4MHz xtal). The counter is reset after 4,5 or 5,5 clock pulses, so there remains an output pulse of 3 μs wide. The 4-or-5 counter is clocked on the Enable input, and counts on the *negative* slope. The 166kHz signal (3μs low/3μs high) is made by an oscillator that is synchronized with a 500kHz signal from the main counter.

Squitter

The 555 is a free running oscillator, with a pseudo random time between pulses (squitter). There shall be 2700 pulses/sec. The interpulse time is set by the random number from a 6-bit linear-feedback shift register (LFSR). The 6 weight resistors are rather equal, making most of the interpulse times 150..250us, with only a few near 500us. After 63 pulses, the pattern repeats itself, so at every $63/2700 = 23\text{ms}$ (43Hz). The longest interpulse time occurs with the LFSR at 000000 , and is set by the lone resistor to +12V. The shortest time occurs in the 011111 state. (111111 does not occur happy enough). Every squitter pulse from the 555 and the reply pulse are shorted to 3us by an RC circuit and added. There is no dead time to separate the reply pulse from an incidental squitter pulse, nor an adjustable reply efficiency, but this can be added later when required.

Beacon identification (ID)

The main timebase provides a 1350Hz pulse with exactly 100μs width. This pulse is XOR'd with itself but delayed by 3μs, yielding a double pulse with 100μs separation. This pattern replaces the squitter and reply pulse as long as the ID button is pushed.

In the ARN-21, the 1350Hz signal is decoded and made audible in a speaker connected to the ID output of the control panel.

Pulse doubler

The (3μs) single pulses come from many different RC circuits, and have slightly different widths. The double pulse RC timing starts at the begin of the single pulse, so width variations of the input pulse do NOT influence the spacing. Otherwise random amplitude modulation would be visible in the ARN21

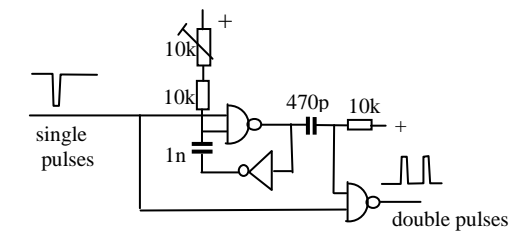

The twin output pulses still have slightly different widths, but these are all made equal in the output cosine pulse shaper.

Modulator and cosine shaper

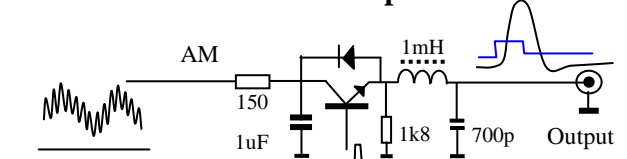

The modulator transistor switches the AM wave to the output LC circuit for approx. 3μs. During this time, the output capacitor is charged to twice the AM voltage (18V max).

After the modulator pulse, the output capacitor discharges via the diode. The basewidth of the pulse is approx. 5μs, the half-height width is 3μs, nearly independent of the modulator control pulse width.

The output pulse has a cosine shape, pretty close to the gaussian shape received from a real beacon. The pulse shall be applied in parallel to the output of the IF module of the ARN21, mixing-in very nice some noise with the simulated waveform.

Adjust the amplitude of the simulator waveform such that the AGC voltage is approx. -3V.

Azimuth reference indicator

A handy extension of the TACAN beacon simulator is a ring of LEDs, placed on top of the azimuth indicator ID 307 or similar. The ring has 90 green leds, so $360 / 90 = 4$ degrees per led. Only one of the 90 leds is on, indicating what the TACAN should indicate.

This ref indicator is connected to the simulator board via a 10-wire cable. The leds are connected in a matrix, and driven by two decoders. One (CMOS, CD4028) chip having only one output **high**, the other chip is a TTL type 74145 with only one output **low**, see the attached diagram.

The TTL chip has open collector outputs, and requires 5V for VCC and input bits. The CMOS chip requires 12V for VCC and input bits.

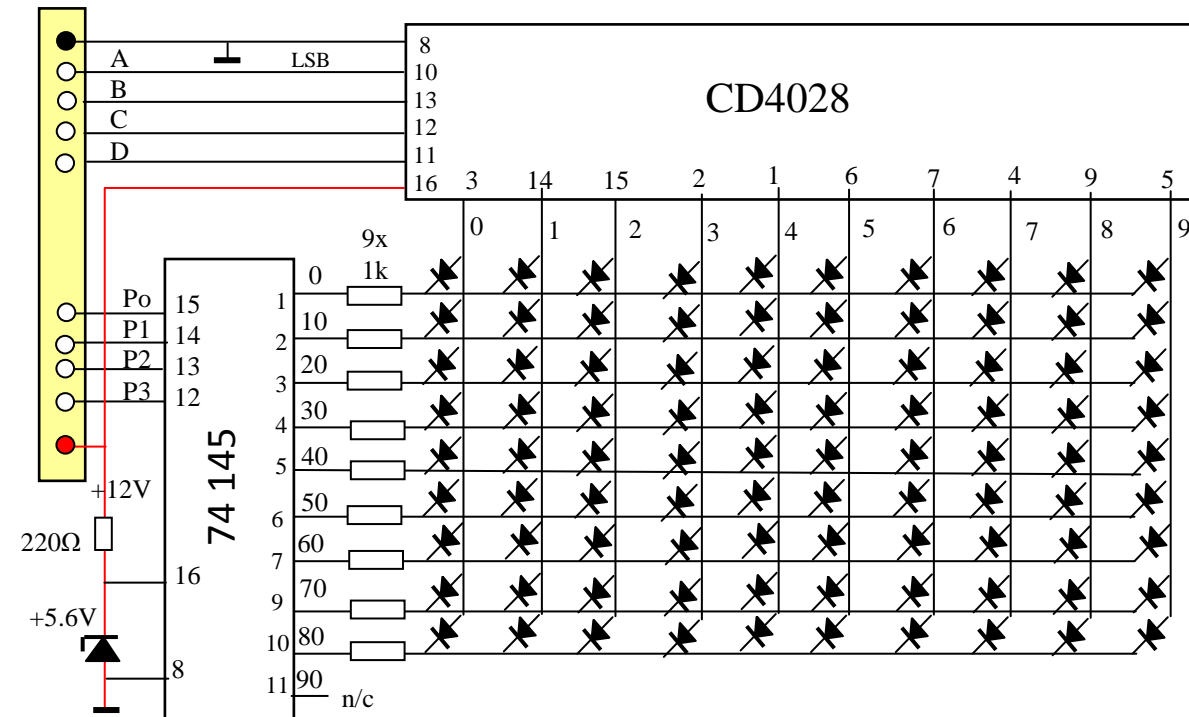

I used cheap 3mm leds. These are slightly wider, so I had to file away the excess width on all leds. The 9 printed circuit strips have 0.1" pitch (2.5mm) which is smaller than the pitch of the leds. I compensated this with the led arrangement as shown in the pattern below.

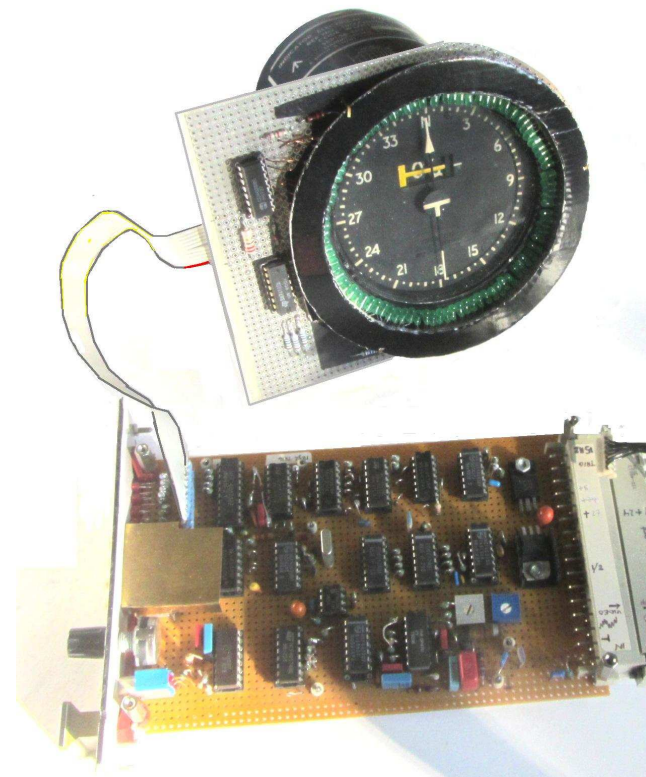
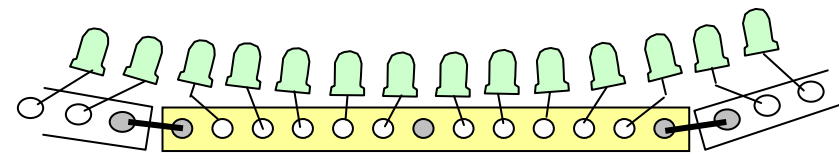

Construction

The reference indicator is built on a 10 x 13 cm experiments board, single side copper is sufficient. The led matrix is realised on 9 strips of perforated printed circuit board, each strip measures 7 x 35mm, and has 3 x 13 holes in a 0.1" pattern.

The interconnections are done with 0.4mm enameled wire.

