

RT-178 / ARC-27 All schematics

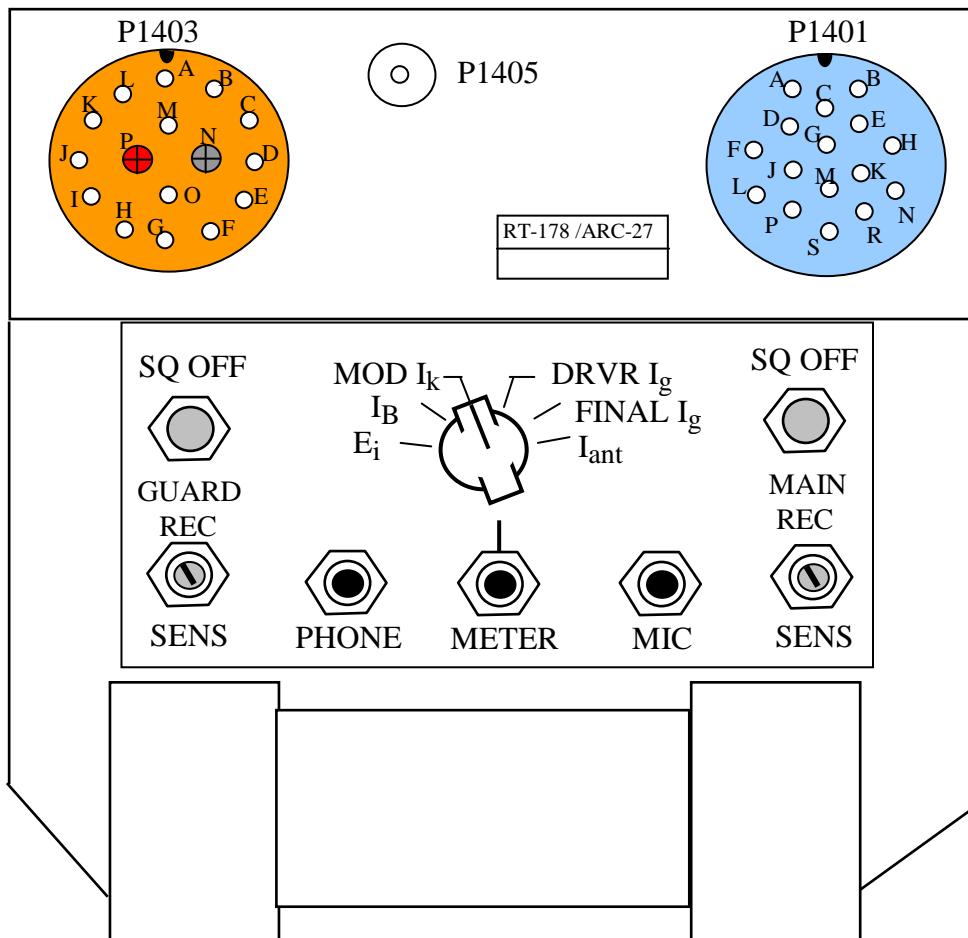

Phone 300Ω 0.5W (2W max.)
 Mic 25 Ω Carbon

Antenna (P1405) 50Ω 10W
 Meter 1mA / 100Ω (external meter !)

P1403 (insert 24-7)

A 10MHz bit a *shaft h*
 B 10MHz bit b
 C 10MHz bit c
 D 10MHz bit d
 E
 F
 G 10MHz bit e
 H 10MHz ambiguity
 I 27,5V for ADF
 J 1MHz bit g *shaft j*
 K MIC input
 L 230Vdc for ADF
 M ADF time constant
 N gnd
 O sens
 P +27.5V / 25A

P 1401 (insert 24-5)

A 1MHz bit j
 B tone relay
 C 1MHz bit i
 D guard relay
 E T/R switch
 F 100kHz bit l, *shaft k*
 G Carrier received
 H on/off relay
 J audio out Phone
 K aux audio out
 L 100kHz bit o
 M 1MHz bit k
 N AVC test
 P 1MHz bit h
 R 100kHz bit n
 S 100kHz bit m

Frequency coding on next page

ARC27 Frequency coding

10Mc coding

	20 38	21 39	22 -	23 -	24 -	25 -	26 -	27 -	28 -	29 -	30 -	31 -	32 -	33 -	34 -	35 -	36 -	37 -	Pin P-1403
a	X			X					X	X	X	X		X	X		X		A
b		X			X					X	X	X	X		X	X		X	B
c	X		X			X					X	X	X	X		X		X	C
d		X		X			X					X	X	X	X		X		D
e	X		X		X			X					X	X	X			X	G
f	*	*	X	X		X	X		X		X		X	X	X	X			H

An "X" indicates that this line connects to ground in the control panel

The remaining lines except line f are interconnected in the control panel

* grounded for 20 and 21, but open for 38 and 39 times 10 Mc

The open circuit seeking switch in the RT-178/ARC27 has 18 positions and makes 2 cycles. The 16 unused positions of the second cycle are skipped automatically

1 Mc coding

	0	1	2	3	4	5	6	7	8	9	pin
g			X			X	X		X		J (P-1403)
h				X			X	X		X	P (P-1401)
i	X				X			X	X		C „
j		X				X			X	X	A „
k	X		X				X			X	M „

The meaning of X in the 1Mc coding depends on the 0.1Mc selection.

For xxx.0 thru xxx.4, the "X" lines **connect to ground** in the control panel

The remaining lines interconnect

For xxx.5 thru xxx.9, the "X" lines are interconnected in the control panel

The remaining lines **connect to ground** in the control panel

The inverted codes cause the 1Mc positioner to make a "half" step to tune the 20-30Mc first IF amplifier which has 500kc bandwidth

The RT-178/ARC27 open circuit seeking switch has 14 positions. The 4 unused are skipped automatically

0.1 Mc coding

	.0	.1	.2	.3	.4	.5	.6	.7	.8	.9	Pin P-1401
l	X		X				X		X	X	F
m	X	X		X				X		X	S
n	X	X	X		X				X		R
o		X	X	X		X				X	L

An "X" indicates that the line connects to ground in the control panel

The remaining lines are interconnected in the control panel.

The RT-178/ARC27 open circuit seeking switch has 14 positions. The 4 unused are skipped automatically

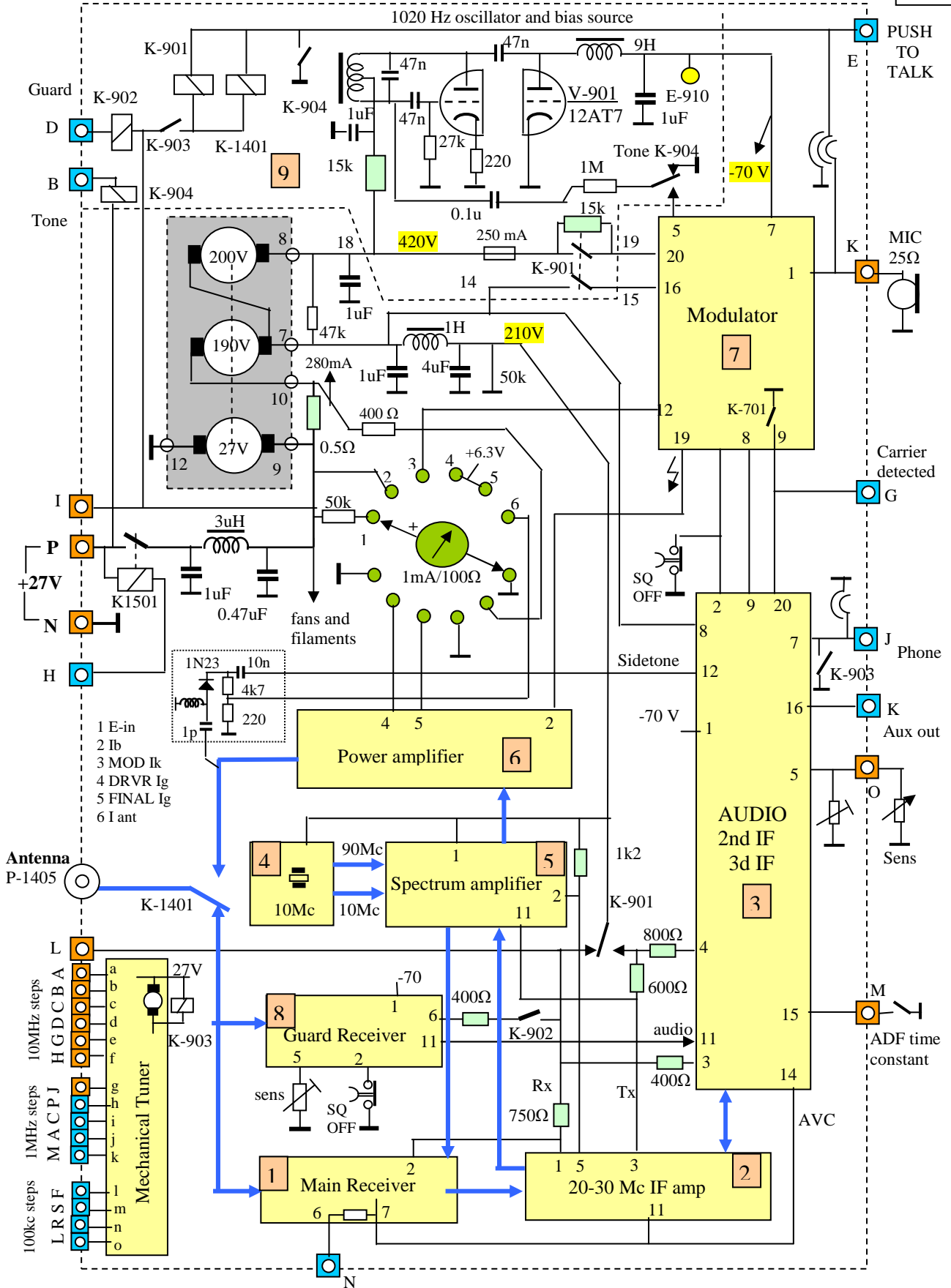

- Coax
- Plug P 1401 on front
- Plug P 1403 on front

RT-178 / ARC-27 Main Chassis
19 aug 2011 kb

RT-178 / ARC-27

Introduced in 1952

Frequency range	225 – 399.9 MHz in 1750 steps of 0.1 Mc
Tunable:	200 – 399.9
Transmitter	10W power into 50 Ω
	Modulation AM, or 1020Hz tone
Receiver	1.2uV for 6 dB S/N
Guard Receiver	2.5 uV for 6 dB S/N
Audio output	2W max, 0.5W at <10% distortion

Modules

- 1 RF receiver amplifier
- 2 20-30Mc IF
- 3 Fixed IF and LF amplifier
- 4 Spectrum oscillator
- 5 Spectrum amplifier
- 6 RF Power Amplifier
- 7 Modulator
- 8 Guard Rx
- 9 Tone, bias and rela

1

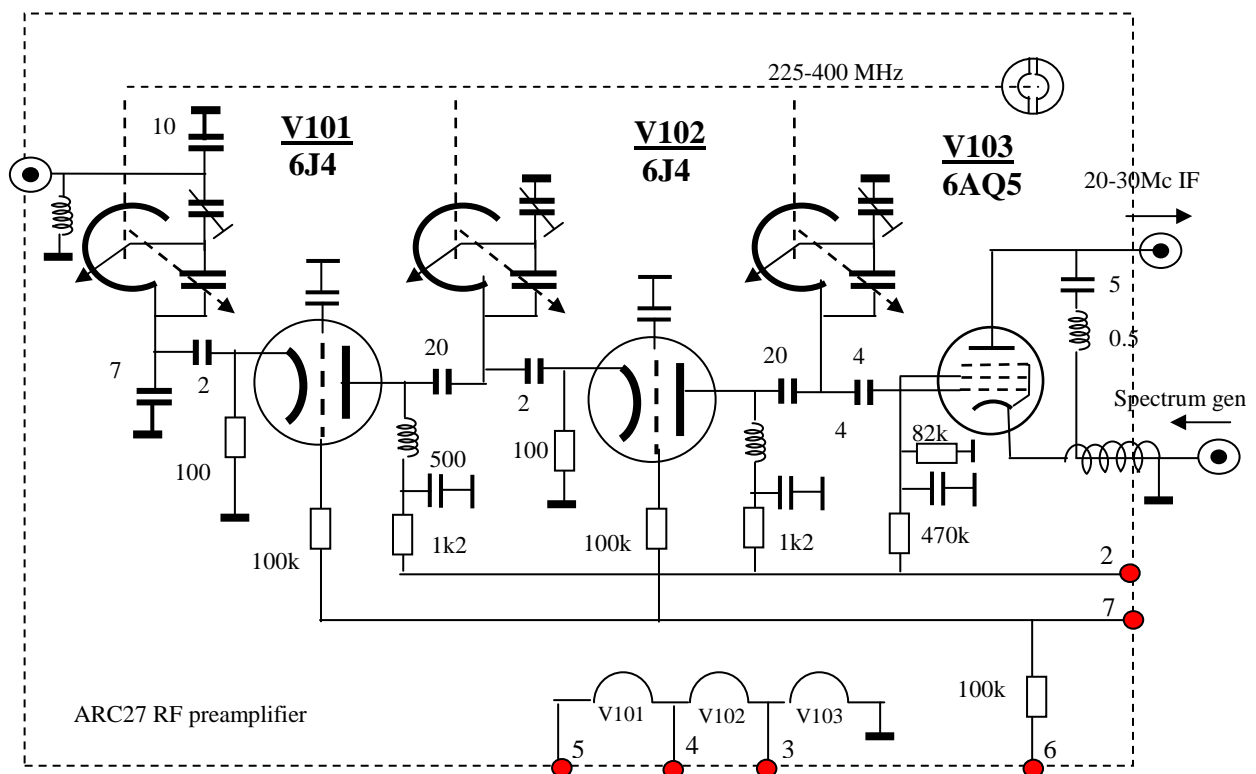

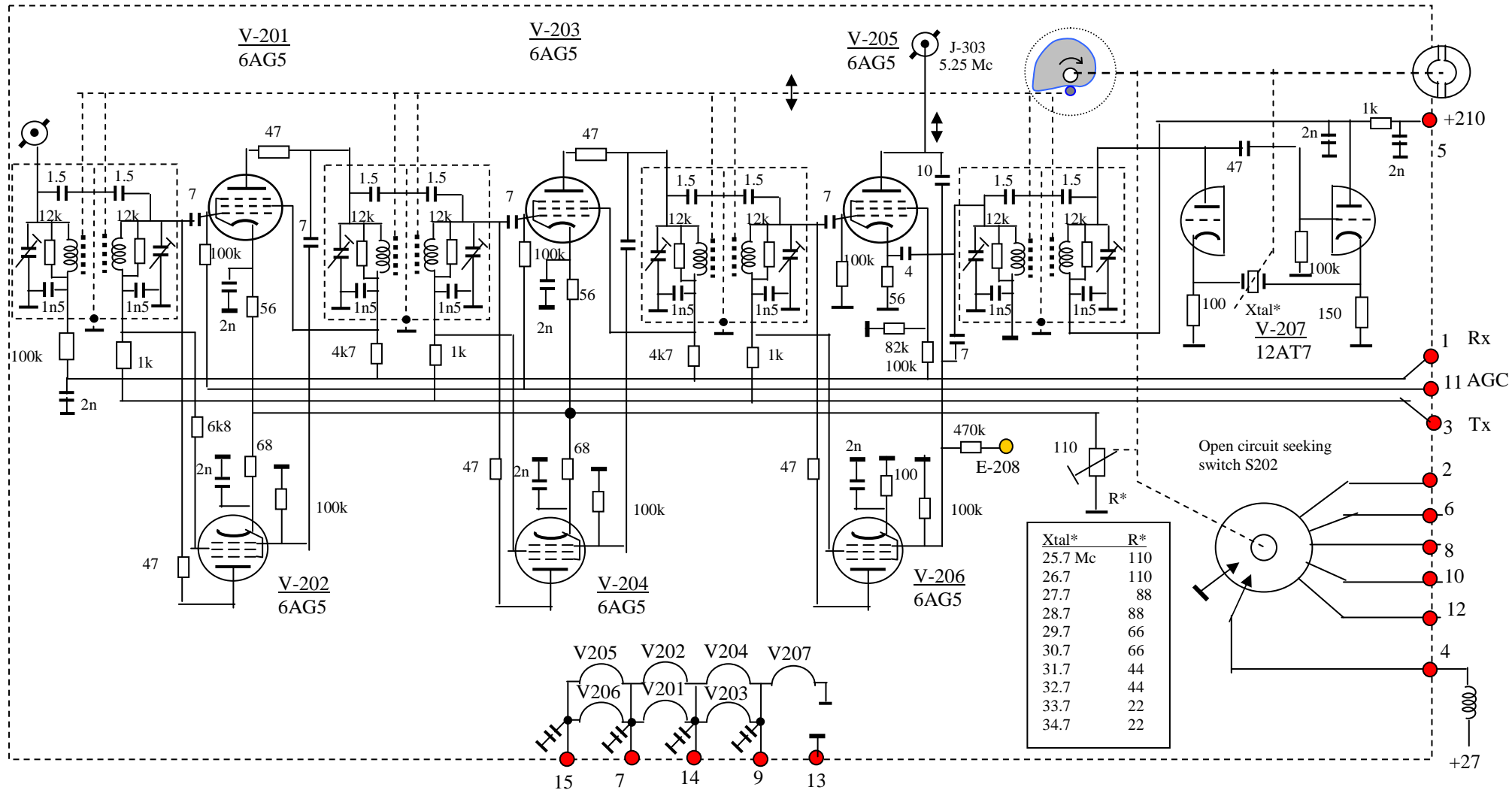

ARC27 20-30 Mc IF Amplifiers
18-3-2011 kb

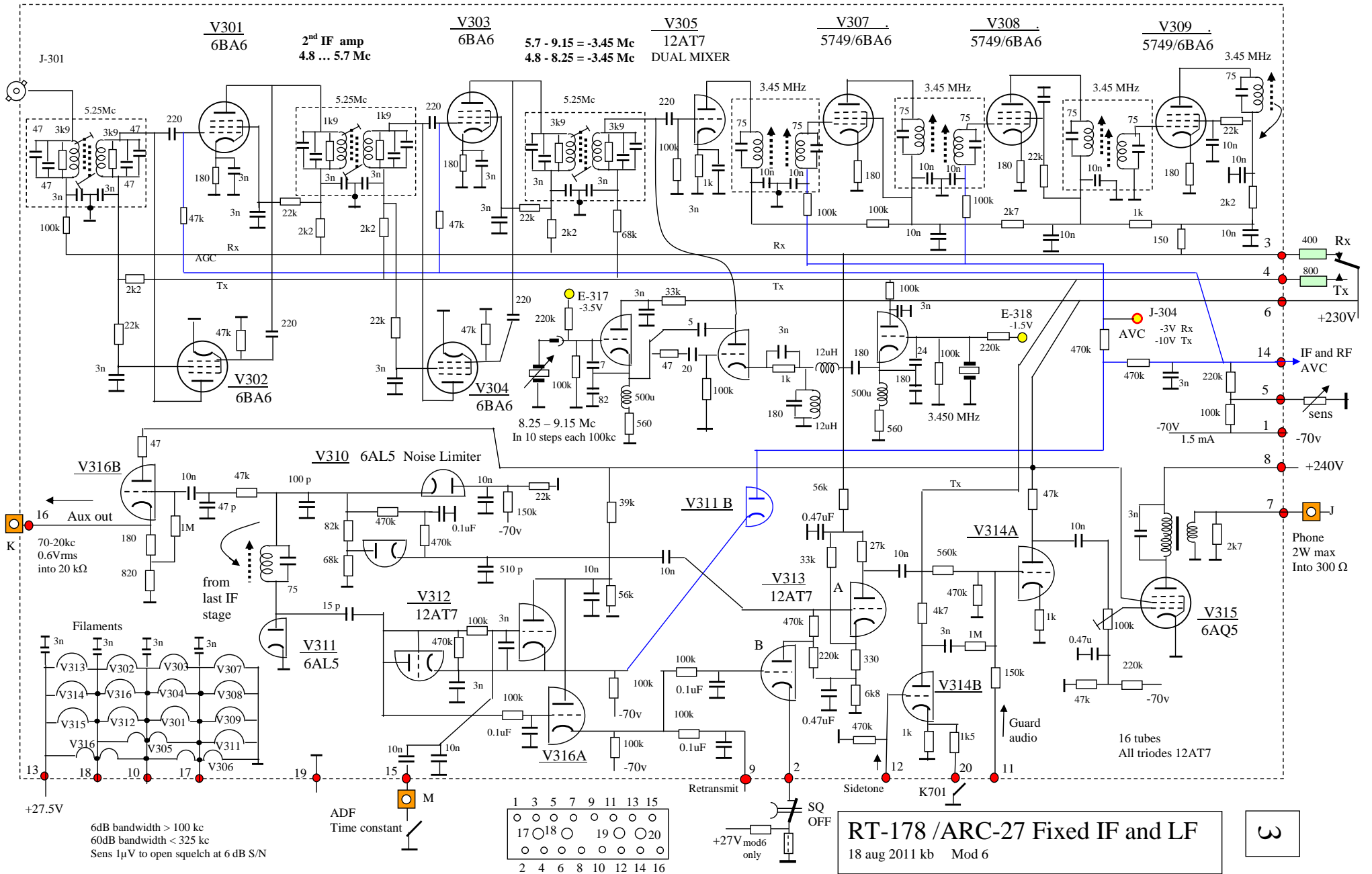

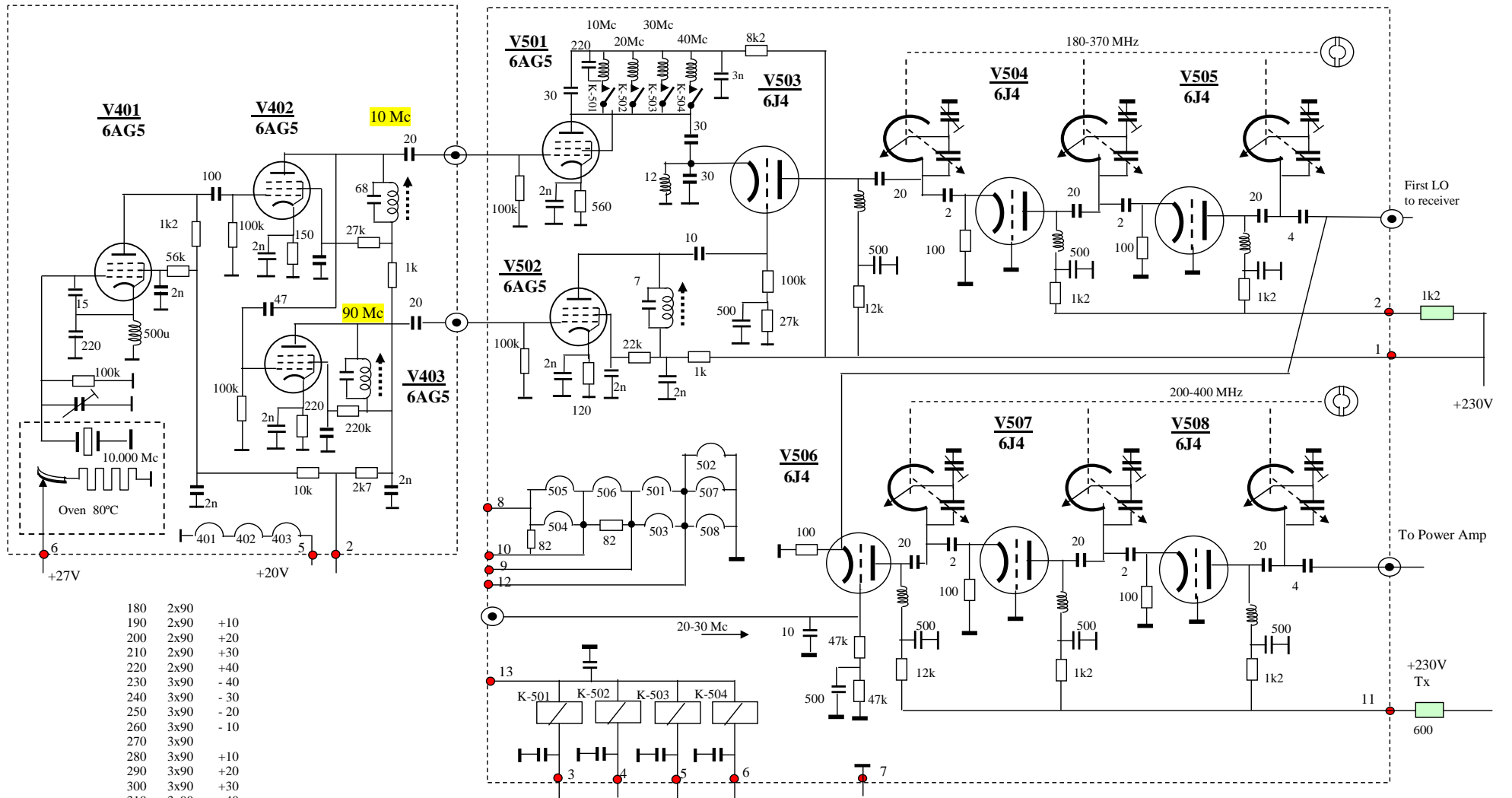

180	2x90	
190	2x90	+10
200	2x90	+20
210	2x90	+30
220	2x90	+40
230	3x90	-40
240	3x90	-30
250	3x90	-20
260	3x90	-10
270	3x90	
280	3x90	+10
290	3x90	+20
300	3x90	+30
310	3x90	+40
320	4x90	-40
330	4x90	-30
340	4x90	-20
350	4x90	-10
360	4x90	
370	4x90	+10

RT-178/ARC-27 Spectrum generator and amplifier

POWER AMPLIFIER

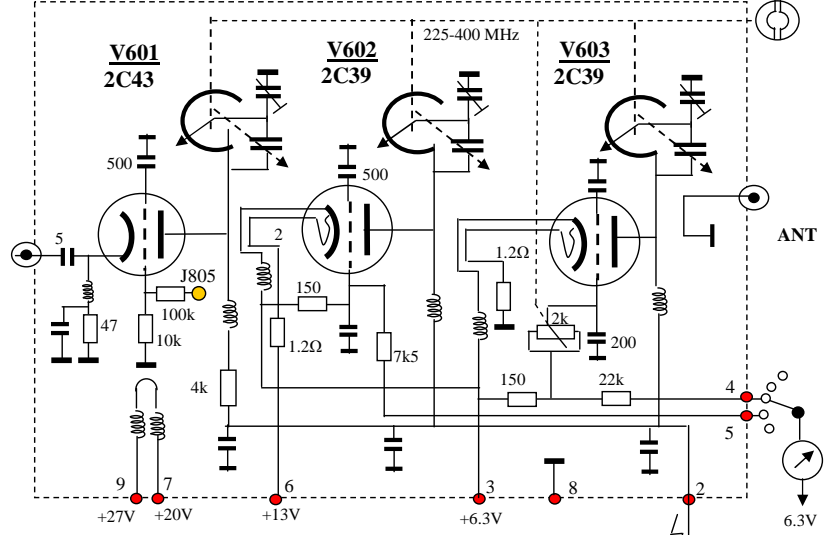

MODULATOR

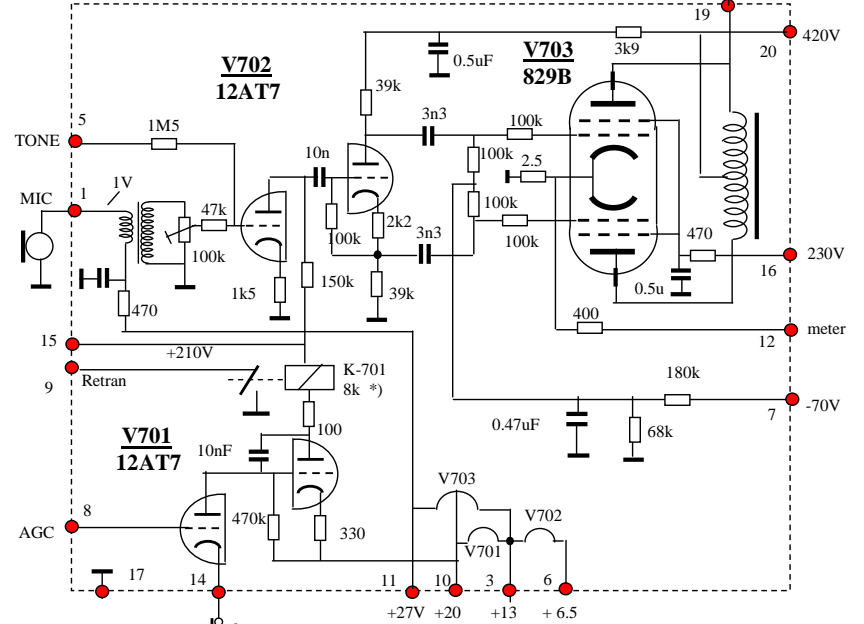

SQ OFF
*) Relay K701 is optional, only fitted in sets for automatic retransmission

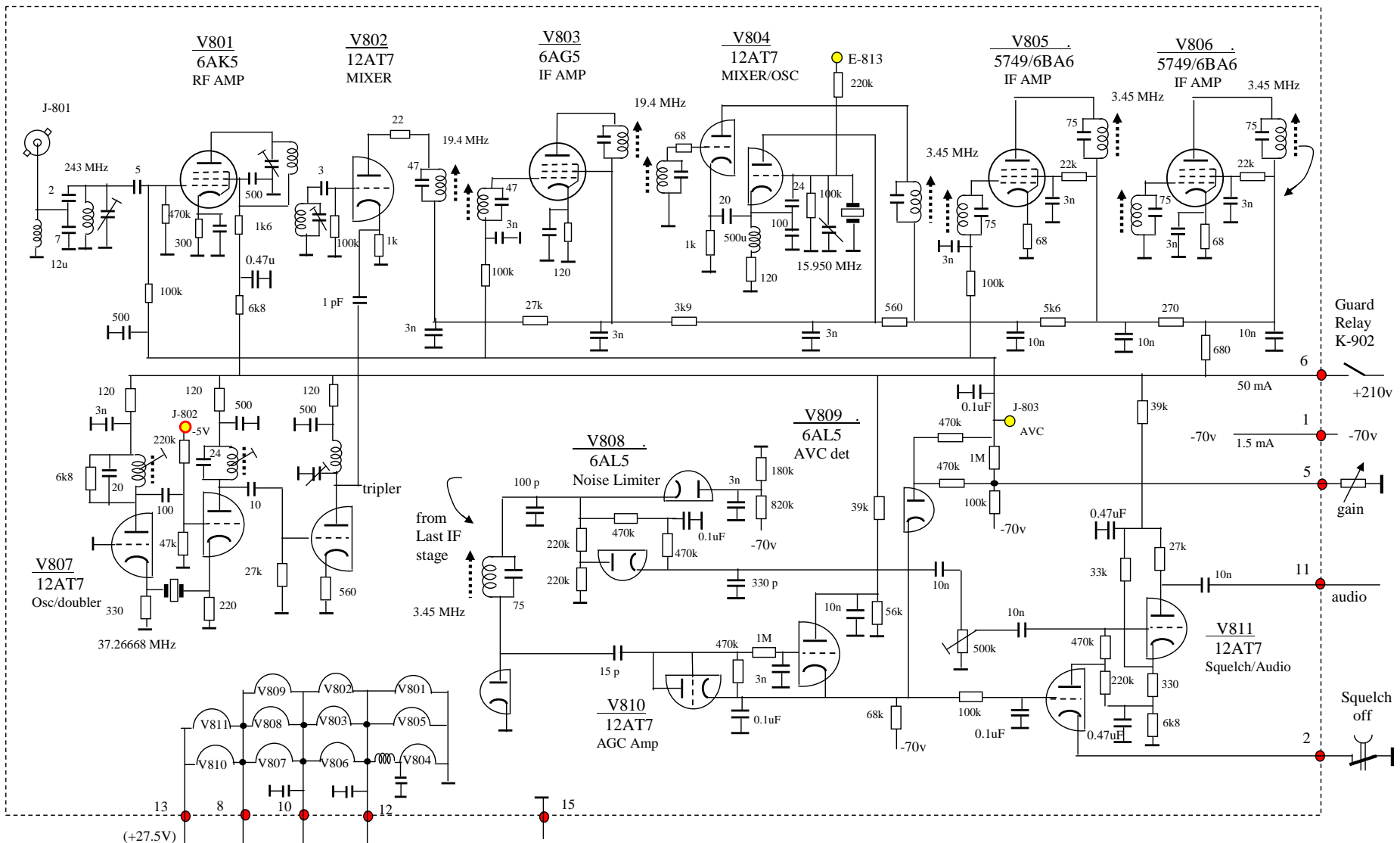

6dB bandwidth > 100 kc
 60dB bandwidth < 325 kc
 Sens 1.2µV to open squelch at 6 dB S/N

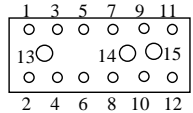

ARC-27 Guard Receiver
 8 aug 2011 kb



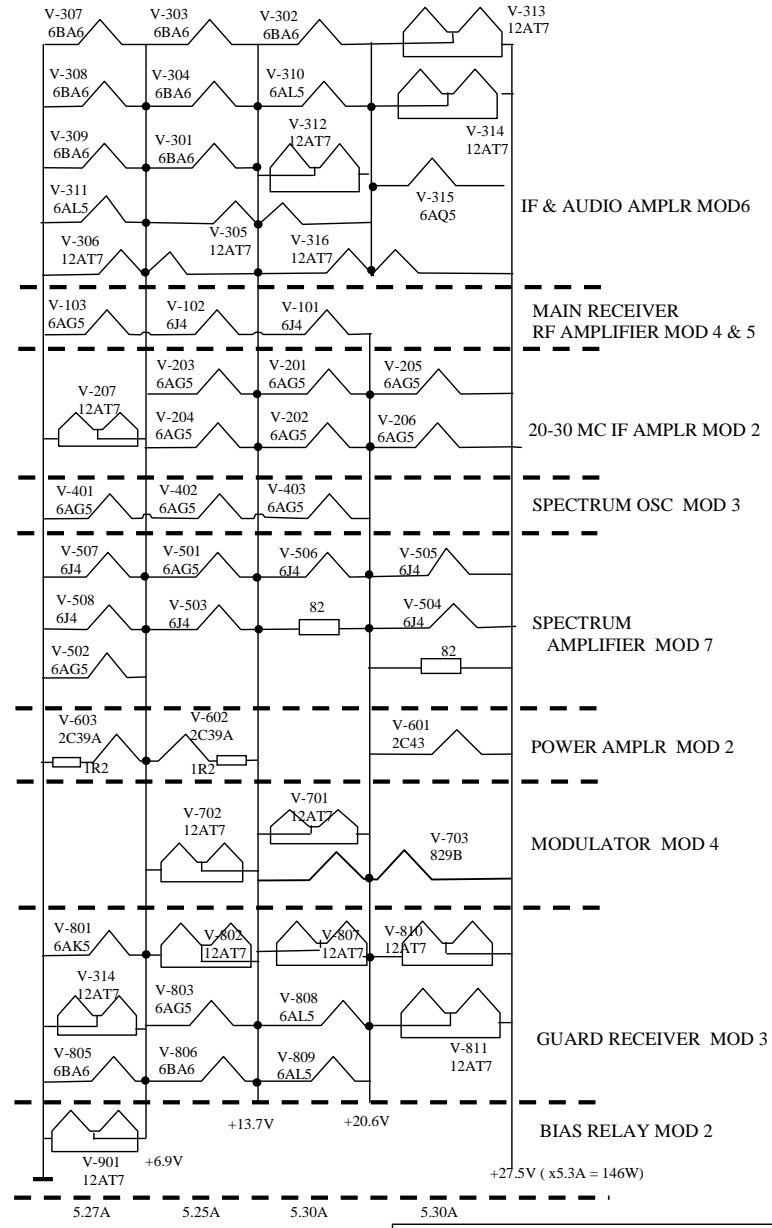

Filament circuit RT-178 / ARC27