

**RT220B / ARN-21 RF modules**  
3 april 2007

## RT220B RF circuits

### Frequencies

The airborne TACAN receiver/transmitter RT220 transmits (downlink) on 126 channels between 1025 and 1150 MHz. Receiving (uplink) is 63MHz *lower* than the downlink for the first 63 channels, and 63MHz *higher* for the last 63 channels.

All channels are crystal controlled, and should occupy less than 1MHz bandwidth. The ground station has proper filters to do so, but the modulator in the RT220B (and RT220C) only approximates the ideal shape for the transmitted pulses. Back in 1956, the only pulse shape requirement was 1µs rise time and 3µs width.

### Channel selection, mechanical links

The RT220B has a turret with 42 crystals that makes 3 complete revolutions for all 126 channels.

*In these 3 revolutions*, a lot of mechanical coupled activity occurs:

- A course pot makes one turn, and a fine pot makes 13 turns;
- Pistons in the 2C39A cavities travel over 16mm, tuning the anode cavities from 1025 to 1150 MHz;
- Central pins in 2 pairs of preselector cavities travel over 16mm, one pair tunes from 962 to 1087MHz, the other pair from 1088 to 1213MHz;
- a micro switch shorts the second pair in the first 63 channels, or the first pair in the last 63 channels;
- another micro switch turns on a 42 MHz oscillator in the 1st and 3d revolution of the turret.



Preselector with antenna input left, and mixer diode on the right under the solenoids which short either the upper or the lower two cavities.

### Remote channel selection

The cockpit controlpanel has two rotary switches that act exactly like the fine and coarse pots coupled with the turret. A smart control system activates the forward/reverse relays of the motor such that the positions of the local and remote pots become equal. The maximum channel selection time ( from ch.1 to ch.126) takes 9 seconds. More precisely, it takes 80ms from channel-to-channel plus 50ms overshoot (half a channel), plus 40ms to step back from the overshoot.

### Local Oscillator string

The 42 crystals have frequencies from 39.518 to 41.037 MHz in 1/27 MHz steps. Following the oscillator, there are 3 triplers, with a buffer between each one. The last tripler is a grounded grid triode 2C39A in a fixed-tuned anode cavity, repeating 3 times 1067 - 1108 MHz while passing ch 1- 126. In the middle revolution of the turret (channels 43-84) this is also the transmit frequency. In the first revolution, a 42 MHz signal is subtracted from the last tripler signal, producing the transmitter frequencies 1025 - 1066 MHz for the channels 1-42. In the last 42 channels, ch. 85-126, the 42 MHz signal is added, producing 1109-1150 MHz.

### Power amplifier

The power amplifier has 3 stages with a 2C39A, and has 30dB gain (2W input, 2kW output). The cavities have a low loaded Q. The first stage has always some anode voltage to provide the LO signal for the mixer between the pulses. The last 2 stages only get anode voltage (+2.5kV) during the transmit pulses.

### Preselector

The pre-selector cavities provide image rejection, and prevent blow-up of the mixer diode during the 2kW transmitter pulses, just 63MHz away from the receiver frequency.

The bandwidth of each 2-cavity preselector filter is about 7 MHz. Still about 1W leaks to the mixer, but with opposite phase (?) to the LO signal.

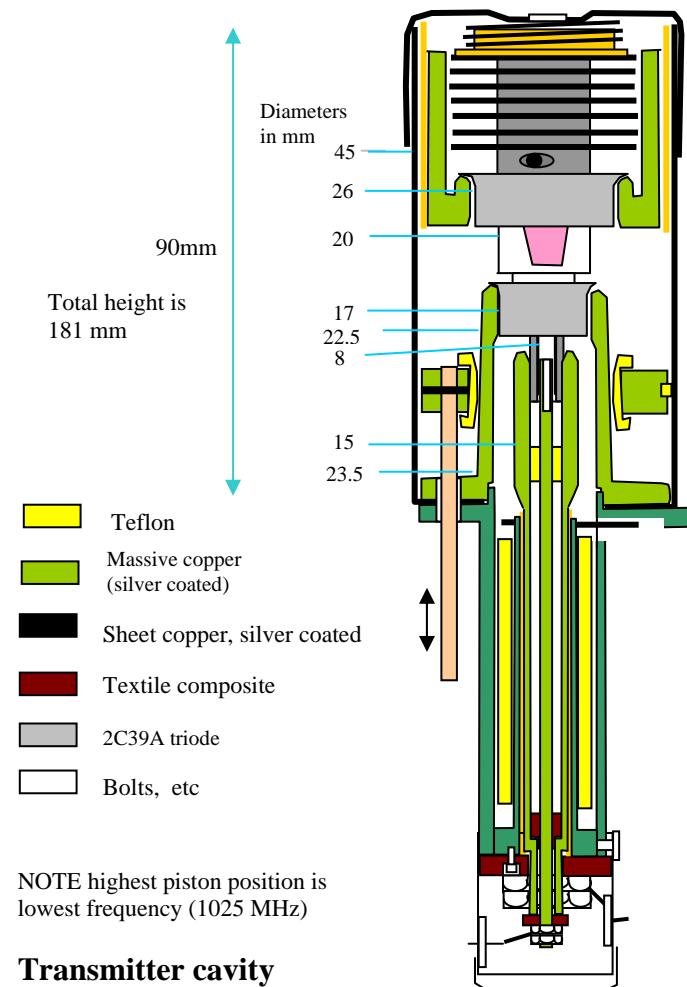

### IF amplifier

The IF amplifier has a cascode input stage, 5 stages with 6AK5, and one video amplifying stage, also with an 6AK5. The total gain is 120dB, or 10x per stage.

In the RT220B, the detector is just a single diode, which assumes a ground beacon with well shaped Gaussian pulses. The preceding RT220A had a Ferris discriminator, which has positive output for signals within its own channel, but negative output for signals on the neighboring channels. This prevents crosstalk from these channels in the early days that ground beacons transmitted rectangular pulses.

The RT220B and 220C bandwidth is 1MHz, adapted to 3µs wide Gaussian pulses. With the AGC wide open (-1.7V) an input of 1µV produces 10Vpp video (and 5Vpp noise)

The group delay of the preselector + mixer + IF module is 6µs. Together with 3µs delay in the video processing, the range instrument displays "zero" when echo's arrive 50+12+6+3 =71µs after the first interrogation pulse is sent.

The mixer diode current can be measured on a testpin near the BNC input of the IF strip. When the LO string works well, approx. +5mV should be measured here across 10Ω. In my RT220B, I got 0.8mV on the first 50 or so channels, and +4mV for the last 70, all in REC mode, and with *open* antenna plug. The mixer diode current might be higher with a proper terminated antenna connector, and is surely higher in T/R mode.

### AGC and muting

The gain of the IF strip varies over at least 78dB when the AGC voltage is varied from -1.7 to -6V.

With -1.7V, the dc current consumption from the +120V rail is much higher than with -6V. This is even visible on the power consumption of the complete AN/ARN-21B !

During each transmitted pulse and 60µs thereafter, the receiver is muted. This is no problem for the range measurement as the earliest echo arrives at least 50µs after any transmit pulse and is anyhow a strong echo from a nearby beacon..